

Introduction

This instruction sheet contains a parts list and installation information for the Model 4299-2 Dual Unit Adjustable Heavy-Duty Rack Mount Kit. This kit includes all hardware necessary to mount two Model 260x SourceMeter® Instruments in a standard 19-inch rack.

Parts list

Table 1 lists the parts supplied with the Model 4299-2 Dual Unit Adjustable Heavy-Duty Rack Mount Kit.

Table 1
4299-2 part listing

Quantity	Description	Keithley part number
2	Hinge	2602-328
2	Front Rack Ear	2602-333
2	Rear Rack Mount Bracket	2602-334
2	Rack Mount Extension Arm	2602-335
1	Rear Bracket	2304-327
1	Modified Quick Release Pin	FA-352
8	Cage Nut	FA-274
1	"DO NOT DISCARD" Label	MC-345
4	#8-32 X 3/8 LG Phillips Pan Head Screw	8-32X3/8PPH
4	#8-32 X 3/8 LG Phillips Flat Head Screw	8-32X3/8PFH
4	#10-32 X 3/8 LG Phillips Pan Head Sems Screw	10-32X3/8PPHSEM
8	#10-32 X 5/8 LG Phillips Truss Head Screw	10-32X5/8PHTRSH

Installation

The following procedure outlines the installation of the rack mount kit.

WARNING Make sure the instrument that is being installed is in a powered down state with all cables unplugged. Failure to install an instrument in a discharged state may cause an electrical shock or death.

CAUTION To prevent damaging heat build-up, and thus ensure specified performance, adhere to the following rack-mounting precautions:

- Keep the rear exhaust vent and at least one side vent free of any obstructions. Even partial blockage may impair proper cooling.
- **DO NOT** position a device adjacent to the Model 260x that forces air (heated or unheated) into or onto the Model 260x's cooling vents or surfaces. This additional airflow may compromise accuracy performance.
- Allow at least 1U of space at the top and bottom of the Model 260x (see Note below).
- Make sure there is adequate air flow around at least one side of the instrument. Adequate air flow ensures proper cooling. Adequate airflow provides air temperatures that are within about one inch of the Model 260x surfaces to remain within specified limits under all operating conditions.
- **DO NOT** rack mount high dissipation equipment adjacent to the Model 260x that could cause excessive heating to occur. The specified ambient temperature must be maintained around the surfaces of the Model 260x to maintain specified accuracies.

NOTE *1U is a standard vertical spacing and is equal to 1.75 inches. Typical distance between the mounting holes on rack rails is 0.125" (1/8").*

When determining placement within any rack, make sure to adhere to the Caution above. If the rack has only convection cooling, use the following as general guidelines to properly design equipment placement:

- Place the hottest equipment (for example, the power supply), at the top of the rack.
- Place precision equipment (such as the Model 260x) as low as possible in the rack (where temperatures are cooler).
- Add space panels below the Model 260x to help ensure adequate air flow.

Step 1. Prepare instrument.

To prepare the instrument for mounting, remove the handle, the mounting ears, and both rear feet. The following information outlines this process.

1. **Remove the handle** —The handle serves as an adjustable tilt-bail. Adjust its position by gently pulling it away from the sides of the instrument case and swinging it up or down. To remove the handle, swing the handle below the bottom surface of the case and back until the orientation arrows on the handles line up with the orientation arrows on the mounting ears (refer to Figure 1). With the arrows lined up, pull the ends of the handle away from the case.
2. **Remove mounting ears.**
 - Remove the screw that secures each mounting ear.
 - Pull down and out to remove each ear.

Figure 1
Remove handle and mounting ears

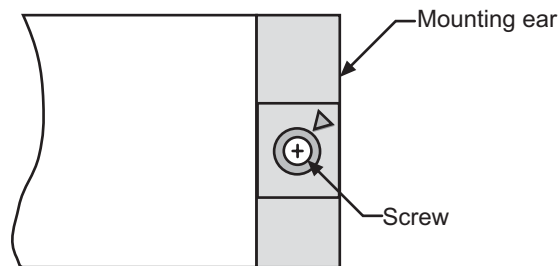
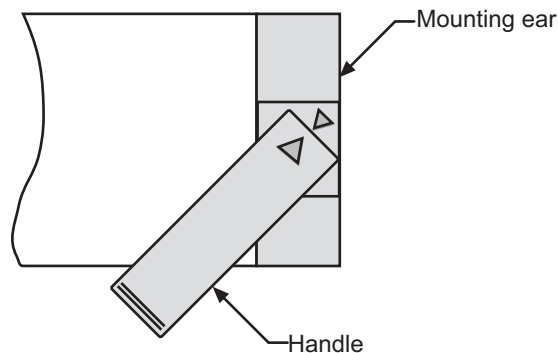

3. **Remove both rear feet from the instrument** by pulling out the rubber feet and then removing the screws underneath.

NOTE *Do not re-install the feet mounting screws. Save all parts removed for future bench top use of the instrument.*

Step 2. Install mounting hardware to instrument.

NOTE *Install the mounting hardware on the rack rail side of each unit (not the same side as the other unit) (see Figure 2).*

1. Determine and select the unit's side that is to be installed closest to the rack rail (see Note).
2. Secure one **Rear Rack Mount Bracket** (2602-334) to each instrument on the selected side using two **Pan Head Sems Screws** (10-32x3/8PPHSEM) (refer to Figure 2).

Figure 2
Attach rear rack mount bracket

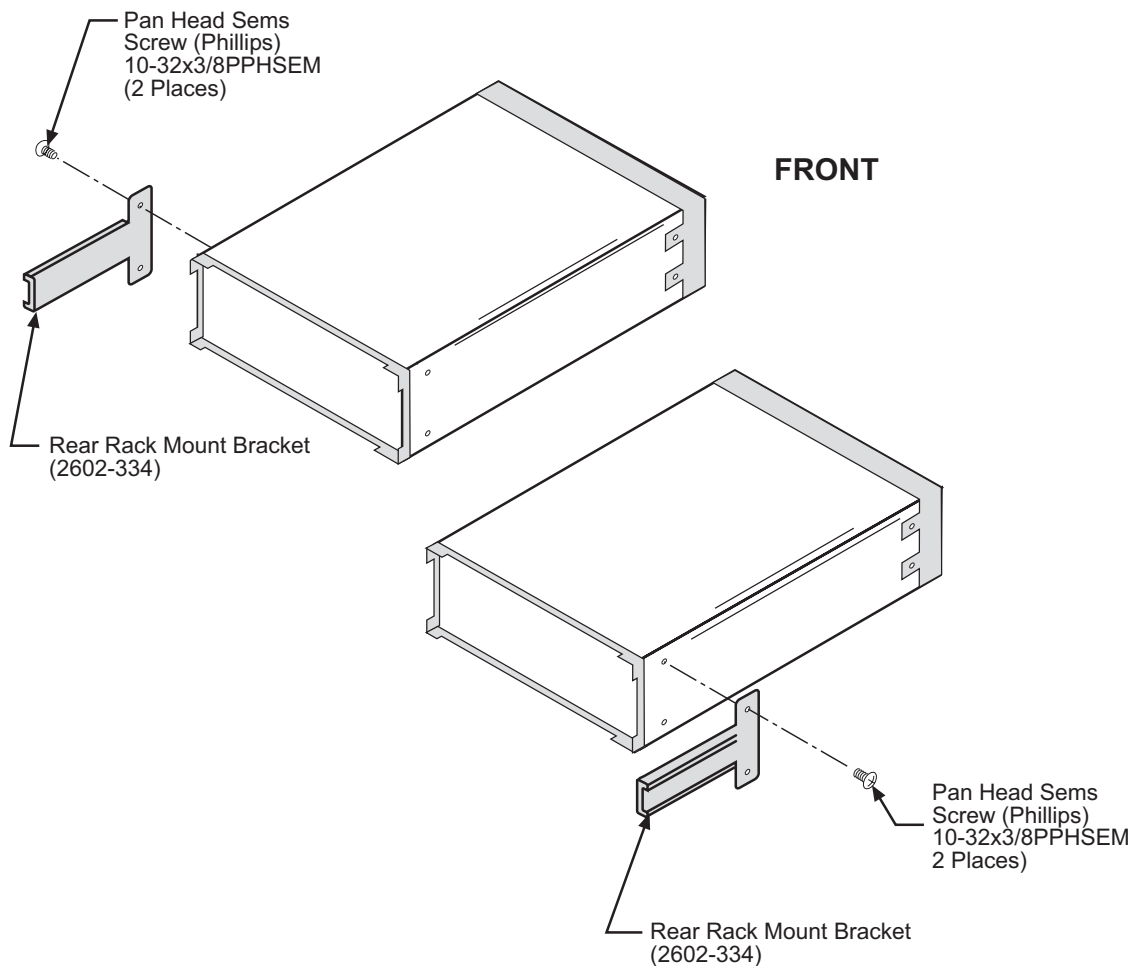

3. Place the instruments side-by-side as they will be installed in the rack (refer to Figure 3).
4. Secure **Front Rack Ear** (2602-333) to outside of each instrument using two **Pan Head Screws** (8-32x3/8PPH) on the same side as the **Rear Rack Mount Bracket** (2602-334).

NOTE Knuckles on **Hinge** (2602-328) must face front of units.

5. Secure one-half of **Hinge** (2602-328) to right instrument and other half of **Hinge** (2602-328) to left instrument using two **Flat Head Screws** (8-32x3/8PFH) on each half. Check knuckle orientation on hinges—knuckles must face front of units.
6. Bring the two instruments together and secure by inserting **Pin** (FA-352) to assemble the **Hinge** (2602-328).
7. Remove one rear bezel screw from each unit as shown (Figure 5). Install the **Rear Bracket** (2304-327) securing it (and the applicable rear bezel) with the removed screws.

Figure 3
Secure instrument together

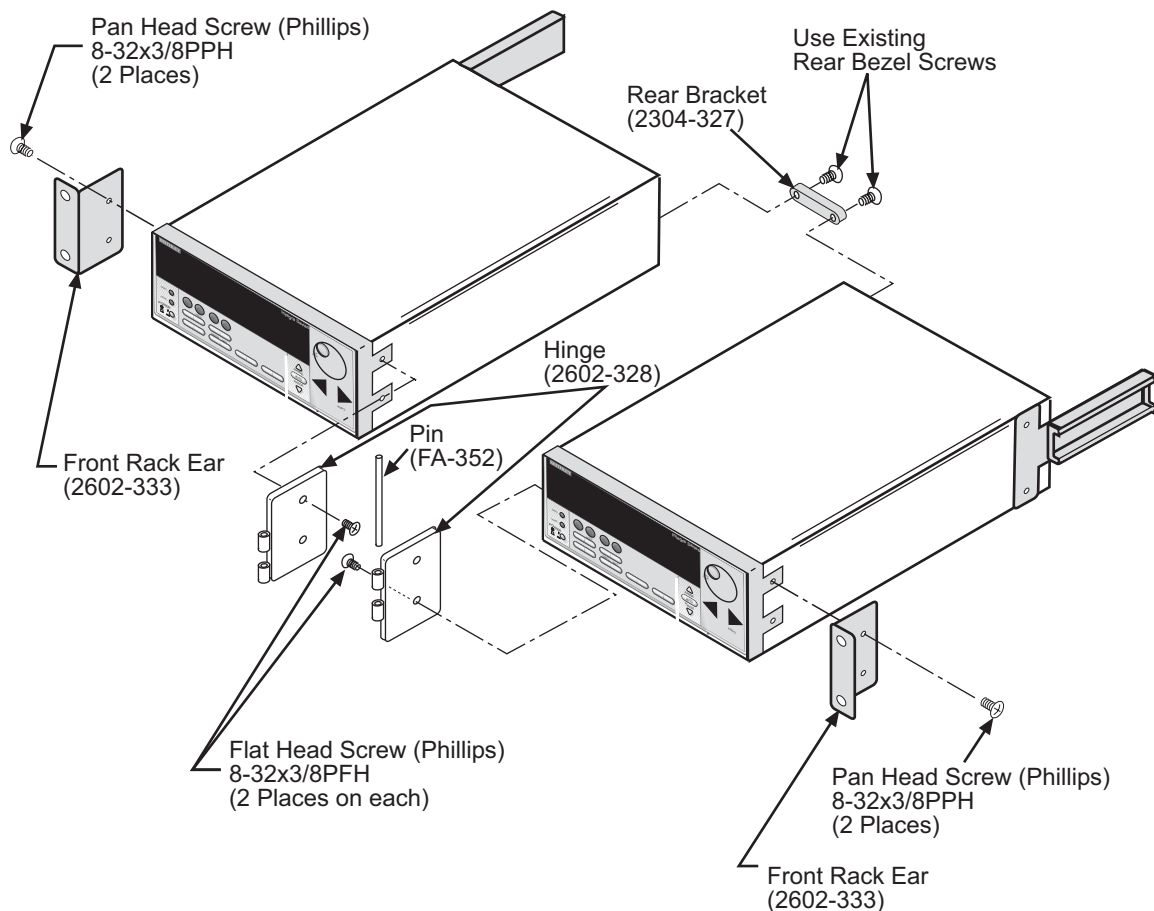

Step 3. Prepare the rack.

1. Install **Cage Nuts** (FA-274) into rack holes to be aligned with the holes in the **Rack Mount Extension Arms** (2602-335) (refer to Figure 4). (The rack holes selected determine unit placement in rack.)
2. Install one **Rack Mount Extension Arm** (2602-335) onto one of the rear rack rails and secure using two **Truss Head Screws** (10-32x5/8PHTRSH).
3. Repeat for other side.
4. Install **Cage Nuts** (FA-274) into front rack rail holes aligned with the rear cage nuts (refer to Figure 4).

Figure 4
Attach rack mount extension arms

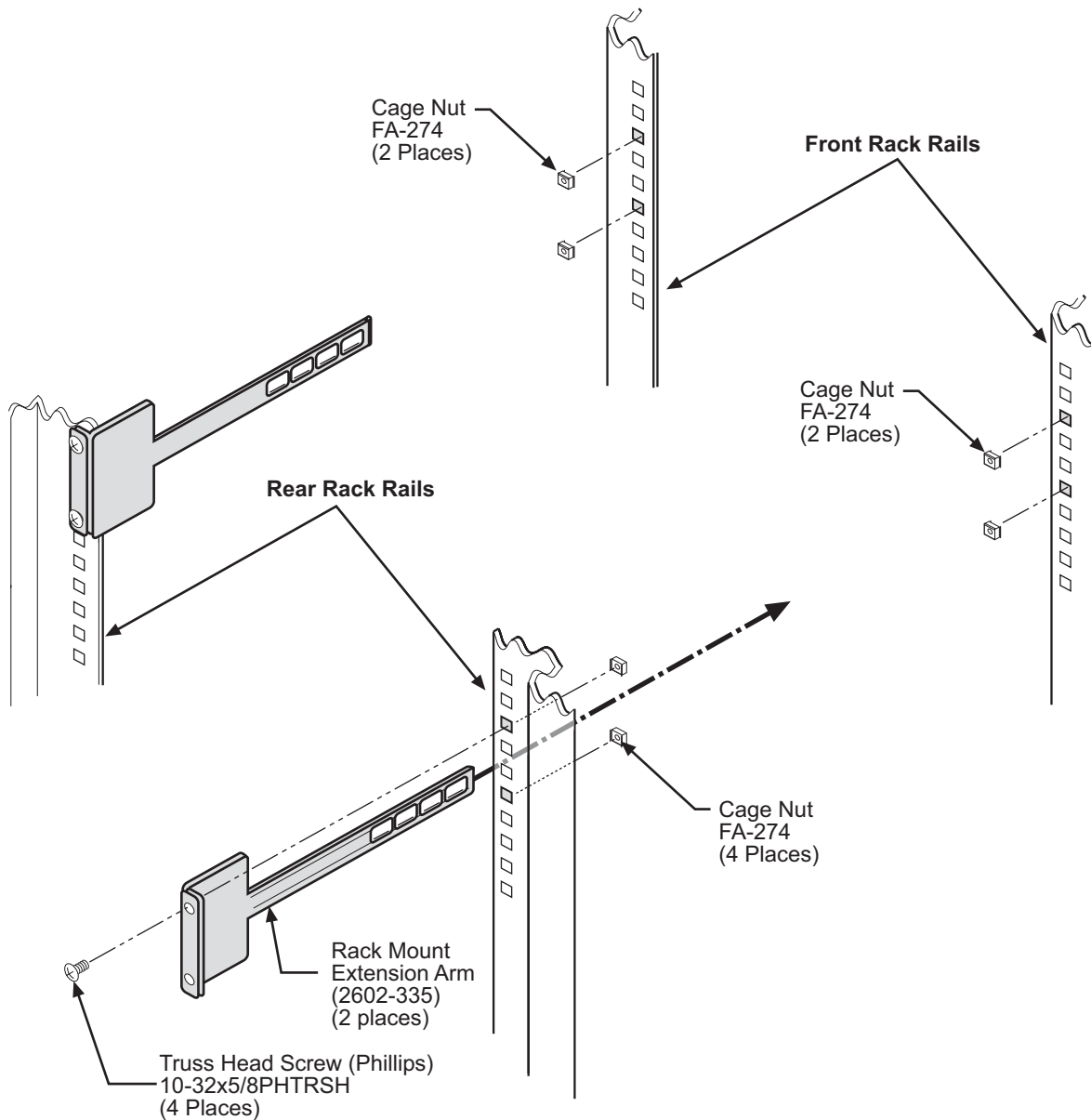

Step 4. Install instruments.

NOTE Although the following step may be completed by one person, two are recommended.

When rack mounting restricts access to the main power cord, provide a separate main power disconnect device. This device must be located in close proximity to the equipment and within easy reach of the operator.

1. Slide units into rack by aligning both **Rear Rack Mount Brackets** (2602-334) with the associated **Rack Mount Extension Arms** (2602-335) (refer to Figure 5).
2. While still supporting the units, secure them to the front rack rails with four **Truss Head Screws** (10-32x5/8PHTRSH).

Figure 5
Install instruments

